

THE FERRUM RANGE

Excellence in Metal
Roofing & Cladding

info@mrc-group.co.za
www.mrc-group.co.za



'SECRET FIX' BUILT UP OR DOUBLE SKIN ROOF SYSTEM – NEW BUILD

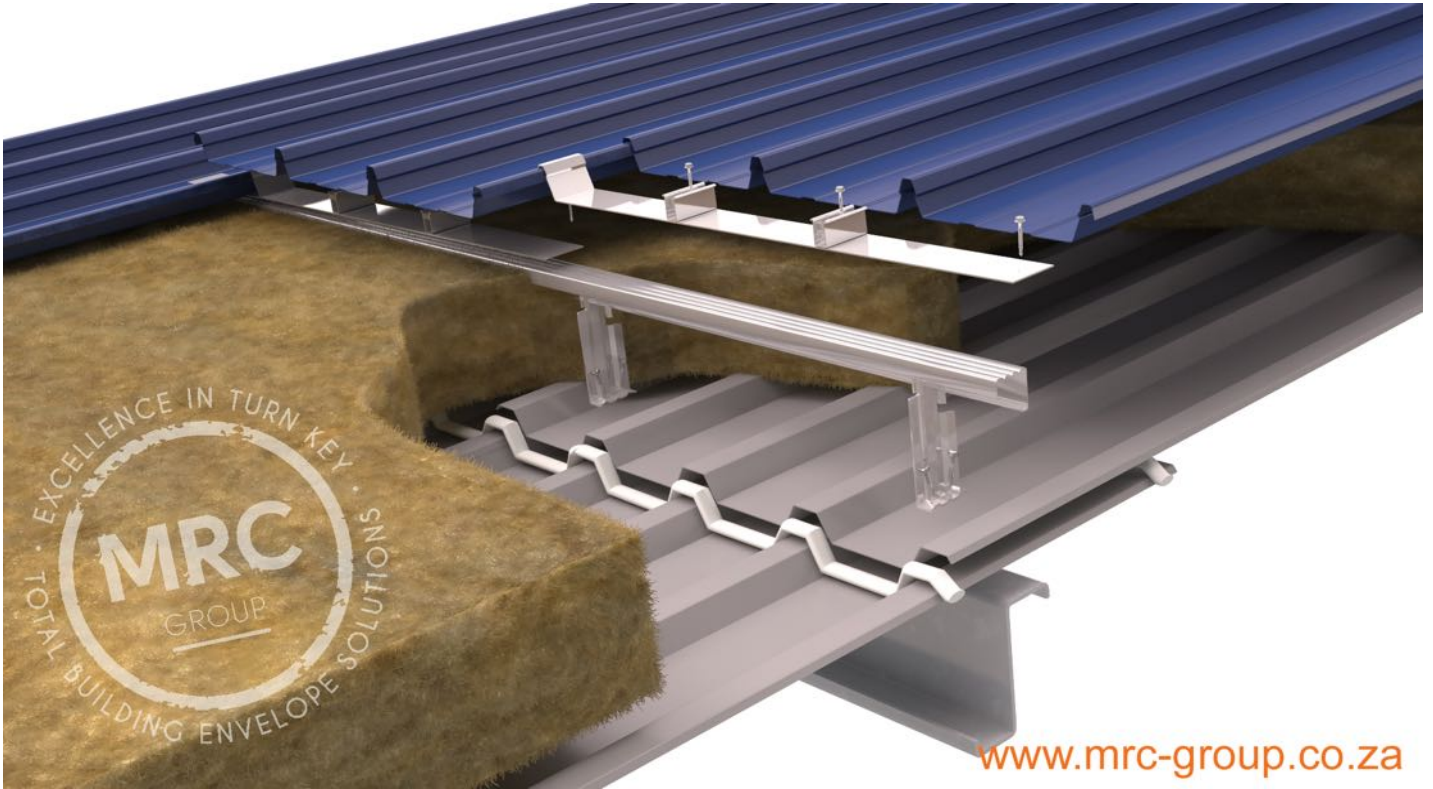

www.mrc-group.co.za

SYSTEM OVERVIEW:

MRC Group's 'Built Up' or 'Double Skin' roof or cladding solutions are at the cutting edge of energy efficient and high performing metal roof systems. A 'built up' metal roof system provides a vast array of options for the most advanced thermal and acoustic performance for buildings.

A 'built up' metal roof system comprises of 2 skins of profiled metal roof sheeting separated by the patented AshGrid™ spacer system forming a structural cavity which is filled with bulk density insulation. The bottom walkable liner provides a clean white soffit to the inside of the building, protection against wind uplift to the external roof sheeting and a safe platform to install the rest of the roof system.

MRC Group's installed system is backed with the unrivalled single source, Guardian™ System Warranty covering materials, installation & maintenance for the term of the roofing and cladding system.

KEY FEATURES:

- Full range of aluminum and steel 'Secret' roof & cladding systems
- R-Value thermal performance up to 10 (m².K/W)
- Excellent weighted sound reduction of 40dB as a standard
- Liner sheet provides restraint to the top flange of the purlin
- Walkable liner provides a safe platform to install the rest of the roof and enables works below
- 'Built Up' roof & cladding systems provide a vast array of solutions
- Backed with the up to 20 year Guardian™ System Warranty

JOHANNESBURG – DURBAN – CAPE TOWN

For project specific specifications, CAD Details, Samples or technical assistance please contact our technical department on +27 (0) 861 672 476 or refer to our Technical Brochure available on www.mrc-group.co.za

All Information correct as of the date this document was created 01 April 2015.

© Copyright 2015 MRC GROUP Copying or reproduction of these material are strictly prohibited

Reference number: MRC/FR/SF/DSM/001

THE FERRUM RANGE

Excellence in Metal
Roofing & Cladding

info@mrc-group.co.za
www.mrc-group.co.za



'SECRET FIX' BUILT UP OR DOUBLE SKIN ROOF SYSTEM – NEW BUILD

TECHNICAL DATA:

ASHGRID™ SPACER SUPPORT SYSTEM

- Brackets with thermal pads - standard height range from 60 – 280mm (Deeper brackets available on request)
- Standard Bar lengths from 1.2 / 2.4 / 3.6 Metres
- 2 No. Self Driller Fixings per Bracket - AshFix Mild Steel 5/16 Hexagonal Head LS25 (Steel Purlins) or TF45 (Timber Battens) Self Driller Fixings, with an integrated 16mm washer flange, fixed through the liner sheet into the structure

THERMAL INSULATION

- Full range of insulation types & thicknesses available
- Fire Classification Class 1 (non-combustible)

R-Value (m ² .K/W)	2.5	3	4	5	6.25
Glass Wool	115mm	135mm	180mm	220mm	280mm
Bracket	115mm	135mm	180mm	220mm	280mm

i.e. Insulation compressed between purlins & roof sheets will lose at least 35% of the proclaimed R-Value, a constant cavity thickness does **NOT** compromise the R-Value

ACOUSTIC DATA – SOUND REDUCTION

- 0.55mm Steel Roof System 40dB +
- 0.8mm Aluminium Roof System 42dB +
- 0.8mm Steel Roof System 48dB +

WEIGHT OF A TYPICAL 'BUILT UP' SYSTEM BASED ON PURLINS AT 1800mm CENTRES

- 2 No. 135mm Bracket per Ln Metre 1.0 kg / m²
- 135mm roll out insulation 1.7 kg / m²
- 0.55mm Secret Fix / Pierced Fix Roof 6.0 kg / m²
- Total Weight 8.7 kg / m²

LINER OPTIONS

- All pierced fix trapezoidal roof & cladding profiles
- Roofing grade timber sheeting or planks

SYSTEM WARRANTY

- Up to 20 year, single source, Guardian™ System Warranty covers Materials, Workmanship & Maintenance

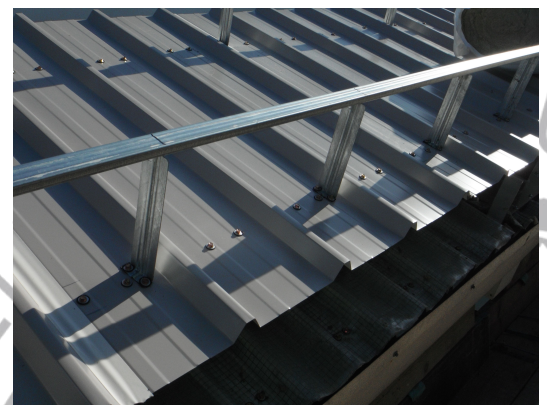
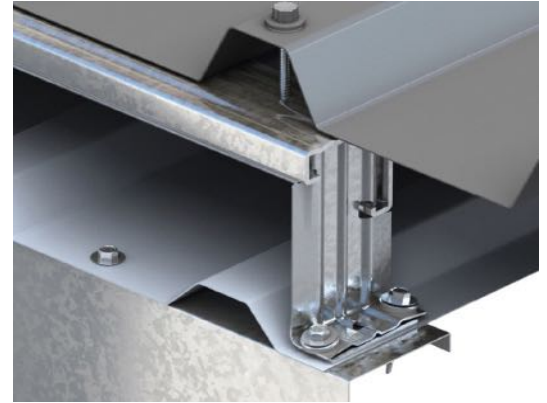

ACCREDITATIONS



MEMBER ORGANISATION 2015

JOHANNESBURG – DURBAN – CAPE TOWN

For project specific specifications, CAD Details, Samples or technical assistance please contact our technical department on +27 (0) 861 672 476 or refer to our Technical Brochure available on www.mrc-group.co.za

All Information correct as of the date this document was created 01 April 2015.

© Copyright 2015 MRC GROUP Copying or reproduction of these material are strictly prohibited

Reference number: MRC/FR/SF/DSM/001